

# Quick Start (en)

Date: 10/2020

Revision: v.2.1

# MiR 1000



# Table of contents

---

<b>1. Version history</b> .....	<b>4</b>
<b>2. Safety</b> .....	<b>5</b>
2.1 Safety message types .....	5
2.2 General safety precautions .....	6
2.3 Intended use .....	10
2.4 Users .....	11
2.5 Foreseeable misuse .....	12
2.6 Residual risks .....	13
2.7 Warning label .....	13
<b>3. Light indicators and speakers</b> .....	<b>14</b>
3.1 Status lights .....	14
3.2 Speakers .....	15
<b>4. IT security</b> .....	<b>16</b>
4.1 Managing users and passwords .....	16
4.2 Software security patches .....	16
<b>5. Getting started</b> .....	<b>18</b>
5.1 In the box .....	18
5.2 Unpacking MiR100 .....	19
5.3 Connecting the battery .....	21
5.4 Powering up the robot .....	26
5.5 Connecting to the robot interface .....	27
5.6 Driving the robot in Manual mode .....	29
5.7 Checking the hardware status .....	31

---

5.8 Mounting the nameplate .....	31
5.9 Shutting down the robot .....	33

# 1. Version history

This table shows current and previous versions of this manual and their interrelations with hardware releases.

MiR100			
			
Revision	Release date	Description	HW
2.0	2020-10-01	Major update and new structure with new chapters: Warning label, IT security, Mounting the nameplate.	5.0
2.1	2020-10-30	Updates and improvements throughout the manual.	5.0

## 2. Safety

Read the information in this section before powering up and operating MiR100.

Pay particular attention to the safety instructions and warnings.



### NOTICE

Mobile Industrial Robots disclaims any and all liability if MiR100 or its accessories are damaged, changed, or modified in any way. Mobile Industrial Robots cannot be held responsible for any damages caused to MiR100, accessories, or any other equipment due to programming errors or malfunctioning of MiR100.

### 2.1 Safety message types

This document uses the following safety message types.



### WARNING

Indicates a potentially hazardous situation that could result in death or serious injury. Carefully read the message that follows to prevent death or serious injury.



### CAUTION

Indicates a potentially hazardous situation that could result in minor or moderate injury. Alerts against unsafe practices. Carefully read the message that follows to prevent minor or moderate injury.



### NOTICE

Indicates important information, including situations that can result in damage to equipment or property.

## 2.2 General safety precautions

This section contains general safety precautions.



### WARNING

If the robot is not running the correct software and is therefore not functioning properly, the robot may collide with personnel or equipment causing injury or damage.

- Ensure that the robot is always running the correct software.



### WARNING

When the robot is in an operating hazard zone, there is a risk of injury to any personnel within the zone.

- Ensure that all personnel are instructed to stay clear of operating hazard zones when the robot is in or approaching the zone.



### WARNING

The robot may drive over the feet of personnel, causing injury.

- All personnel must be informed of the side protective fields of the robot and be instructed to wear safety shoes near an operating robot.



### WARNING

The robot may drive into a ladder, scaffold, or similar equipment that has a person standing on it. Personnel risk fall injuries and equipment may be damaged.

- Don't place ladders, scaffolds, or similar equipment in the robot's work environment.

**WARNING**

The robot may drive down staircases or holes in the floor and cause serious injury to personnel and damage to the robot and to equipment.

- Mark descending staircases and holes as Forbidden zones on maps.
- Keep the maps up to date.
- Inform personnel that the robot cannot detect descending staircases and holes in the floor in time to stop.

**WARNING**

Contact with live electrical parts can cause electric shock.

- Do not touch any internal components of the robot while it is powered.

**WARNING**

Using a charging device different from the one supplied by the manufacturer can cause a fire and thereby burn injuries to nearby personnel and damage to the robot and equipment.

- Only use the original charger.

**WARNING**

Attempting to charge batteries outside the robot can lead to electrical shock or burns.

- Never charge the batteries outside the robot.



## WARNING

Lithium battery packs may get hot, explode, or ignite and cause serious injury if they are misused electrically or mechanically.

Observe the following precautions when handling and using lithium-ion batteries:

- Do not short-circuit, recharge, or connect with false polarity.
- Do not expose to temperatures beyond the specified temperature range or incinerate the battery.
- Do not crush, puncture, or disassemble the battery. The battery contains safety and protection devices, which, if damaged, may cause the battery to generate heat, explode, or ignite.
- Do not allow the battery to get wet.
- In the event the battery leaks and the fluid gets into one's eye, do not rub the eye. Rinse well with water, and immediately seek medical care. If left untreated, the battery fluid could cause damage to the eye.
- Use only the original charger (cable charger or charging station) and always follow the instructions from the battery manufacturer.
- Do not touch damaged batteries with bare hands. Only personnel using suitable Personal Protection Equipment (PPE) and tools should handle damaged batteries.
- Isolate the battery and keep clear if the following conditions are observed:
  - The battery exhibits abnormally high temperatures.
  - The battery emits abnormal odors.
  - The battery changes colors.
  - The battery case is deformed or otherwise differs from the normal electrical or mechanical condition.
- Modifications or manipulations of the battery may lead to considerable safety risks and are therefore prohibited.
- Do not use the battery for anything other than MiR100.





**WARNING**

Load falling or the robot overturning if the load on the robot is not positioned or fastened correctly can cause fall injuries to nearby personnel or damage to equipment.

- Ensure that the load is positioned according to the specifications and is fastened correctly—see the user guide of your robot for payload specifications.



**CAUTION**

Load placed directly on top of the robot cover may cause damage to the cover of the robot.

- Ensure that the load is not placed directly on top of the robot cover.



**CAUTION**

Robot malfunctions can cause an electrical fire, causing damage and injury to equipment and personnel.

- Personnel operating near the robot must be informed on how to use an ABC fire extinguisher to put out an electrical fire should the robot malfunction and catch on fire.



**CAUTION**

Risk of trapping or injury to personnel if robots malfunction or if personnel enter operating hazard zones.

- Personnel operating near the robot must be informed on how to engage the robot's Emergency stop function in emergency situations.



### NOTICE

Moving the robot by hand forcefully may cause damage to the top cover.

- If the robot is stuck, push or pull gently on the top cover corners to move the robot.

## 2.3 Intended use

MiR100 is intended to be commissioned and used in indoor industrial environments where access for the public is restricted.

MiR100 is intended to be commissioned according to the guidelines in your robot's user guide. This is a prerequisite for safe usage of MiR100.

MiR100 is equipped with safety-related features that are purposely designed for collaborative operation where the robot operates without a safety enclosure or together with people.

MiR100 is intended to be used with top modules supported by Mobile Industrial Robots or custom modules that:

- Do not have any moving parts.
- Do not extend the footprint of the robot.
- Operate within the environmental conditions required for MiR100.

If used with custom modules, all obligations of a manufacturer apply to the individual who performs the modifications in accordance with the machinery directive.

MiR100 is designed for and all risks are considered when used with one of the following types of top modules:

- MiR Hook 100 to tow carts.

MiR100 can be used as a partly complete machine as defined in the EU machinery directive, with top modules that do not meet the above limitations. Those who design, manufacture, or commission a system that does not meet the limitations of use of MiR100 carry the obligations of a manufacturer and shall ensure a safe design according to EN ISO 12100. Guidelines outlined in this manual are not sufficient.

The following list gives examples of modules that are foreseeable misuse of MiR100:

- Top modules (including total payload) that increase the footprint of MiR100
- Conveyers (powered and non-powered)
- Industrial robot arms
- Devices that tow carts
- Customized load transfer stations



#### NOTICE

A safe machine does not guarantee a safe system. Follow the commissioning guidelines in your robot's user guide to ensure a safe system.

## 2.4 Users

MiR100 is only intended to be used by personnel that have received training in their required tasks.

There are three types of intended users for MiR100: commissioners, operators, and direct users.

### Commissioners

Commissioners have thorough knowledge of all aspects of commissioning, safety, use, and maintenance of MiR100 and have the following main tasks:

- Commissioning of the product. This includes creating maps and restricting the user interface for other users and making brake tests with a full payload.
- Conducting the risk assessment.
- Determining the payload limit, weight distribution, safe fastening methods, safe loading and unloading of loads on MiR100, and ergonomic loading and unloading methods if relevant.
- Ensuring the safety of nearby personnel when the robot is accelerating, braking, and maneuvering.

### Operators

Operators have thorough knowledge of MiR100 and of the safety precautions presented in this user guide. Operators have the following main tasks:

- Servicing and maintaining MiR100.
- Creating and changing missions and map features in the robot interface.

## Direct users

Direct users are familiar with the safety precautions in this quick start and have the following main tasks:

- Assigning missions to MiR100.
- Fastening loads to MiR100 securely.
- Loading and unloading from a paused robot.

All other persons in the vicinity of MiR100 are considered indirect users and must know how to act when they are close to the robot.

## 2.5 Foreseeable misuse

Any use of MiR100 deviating from the intended use is deemed as misuse. This includes, but is not limited to:

- Using the robot to transport people
- Using the robot on steep surface grades, such as ramps
- Making changes to the SICK configuration
- Driving the robot on cross slopes
- Exceeding the total payload
- Positioning or fastening loads incorrectly according to the specifications
- Using Emergency stop buttons for anything other than emergency stops
- Using the robot in medical and life critical applications
- Operating the robot outside the permissible operating parameters and environmental specifications
- Using the robot in potentially explosive environments
- Using the robot outdoors
- Using the robot in hygiene zones



### NOTICE

If the robot is misused, the warranty becomes void. Only use the robot as described in [Intended use on page 10](#).

## 2.6 Residual risks

Mobile Industrial Robots has identified the following potential hazards that commissioners must inform personnel about and take all precautions to avoid when working with MiR100:

- You risk being run over, drawn in, trapped, or struck if you stand in the path of the robot or walk towards the robot or its intended path while it is in motion.
- You risk being run over, drawn in, trapped, or struck if you stand in the path of the robot or walk towards it while it is driving in reverse. It will only drive in reverse when undocking from a marker such as a charging station or load transfer station.
- You risk being crushed or trapped if you touch the robot while it is in motion.
- You risk being crushed or trapped if the robot places a load outside a designated drop-off area due to faulty localization.
- You risk losing control of the robot if it is accessed by unauthorized users. Consider increasing the IT security of your product.



### NOTICE

Other significant hazards may be present in a specific robot installation and must be identified during commissioning.

## 2.7 Warning label

MiR100 is supplied with a warning label that specifies that it is strictly prohibited to ride on the robot.

The label must be placed on the robot or top module so that it is clearly visible.















Figure 2.1. The warning label must be placed on the robot or top module.

## 3. Light indicators and speakers

The robot uses its status lights and speaker to let people in the environment know what the robot is currently doing or planning to do.

### 3.1 Status lights

The LED light band running all the way around the robot indicates the robot's current operational state. Colors may also be used as part of missions, but as standard, status lights indicates the statuses described in *Table 3.1*.

Table 3.1. Status light colors	
	Emergency stop
	Ready for job
	Drives to destination
	Goal/Path blocked
	Planning/Calculating
	Mission paused
	Startup signal before PC is active
	Shutting down robot
	Relative move, ignoring obstacles
	General error, for example hardware, localization
	Manual drive
	Mapping
	Charging at charging station

White wavering	Prompt user / Waiting for user's response
Cyan wavering (MiR Fleet robots only)	Waiting for MiR Fleet resource



When the robot's battery reaches a critically low level of power (0-1%), the ends of the status lights flash red.



When the robot is charging in a charging station, the status lights on the side of the robot indicate the robot's battery percentage.

## 3.2 Speakers

In **Setup > Sounds**, you can upload new sounds to the robot or edit the volume and length of the default sounds.

Sounds are used in missions and can be used as alerts: “Please step aside” or to attract peoples attention, for example, when the robot has arrived at a position.



### CAUTION

It is the responsibility of the commissioner to ensure that the warning sounds are audible in the robot's work environment.

## 4. IT security

IT security is a set of precautions you can take to prevent unauthorized personnel from accessing MiR100. This section describes the main IT-security related risks and how to minimize them when commissioning MiR100.

MiR100 communicates all data over the network that it is connected to. It is the responsibility of the commissioner to ensure that it is connected to a secure network. MiR recommends conducting an IT-security risk assessment before commissioning the robot.



Contact your distributor for a list of FAQs about IT security.

### 4.1 Managing users and passwords

Managing your users and passwords is the main way you can control access to MiR100.

There are three default users with predefined passwords for you to start using. These are described in the *MiR Robot Reference Guide* along with instructions to create new users, user groups, and passwords. MiR advises you to:

- Change the default password for all predefined users if you choose to continue to use them. Make sure to choose a strong password since MiR100 does not enforce any password rules nor expire the password.
- Create new user groups if more levels of access are necessary.
- Create dedicated user accounts under the relevant user group for each person accessing MiR100, and ensure that the users change the password on their first sign-in. It is not recommended to have several users share the same account.
- Only enable users with a minimum level of access to use a pin code to sign in. Users with a higher level of access are recommended to use a strong password to sign in instead.

### 4.2 Software security patches

To improve the security of MiR100, MiR supplies security patches to the operating system in new MiR software update files. When you install a security patch, it takes approximately 10-15 minutes longer to update a MiR product.





Security patches are included from software version 2.8.3 and higher.

## Understanding MiR software versions

MiR uses the **Major.Minor.Patch.Hot fix** format to version software. For example, 2.8.1.1 means that the software is based on the second major release, the eighth minor release of the major version, the first patch release of the minor version, and, in this example, a single hot fix is included too.

- **Major releases** include the most significant changes that affect the entire robot software.
- **Minor releases** often include new features and smaller changes that only affect parts of the software.
- **Patch releases** focus on fixing small issues in the software and introducing quality improvements.
- **Hot fix releases** are only created when a patch release has introduced a critical issue that needs to be fixed immediately.

## Security patch policy

MiR applies the following policy when supplying security patches:

- New security patches are distributed per every minor release.
- All patch releases under a minor release include the previous security patches also. In other words, if you chose not to install the first software version in a minor release, such as version 2.9.0, the security patches will still be installed when you update to 2.9.1 or higher.

# 5. Getting started

This section describes how to get started with MiR100.



## NOTICE

Read [Safety](#) on page 5 before powering up MiR100.

## 5.1 In the box

This section describes the contents of the MiR100 box.



Figure 5.1. The robot and accessories

The box contains:

- The MiR100 robot
- The robot kit which contains:
  - One Emergency stop box, external antenna, and four pcs. M10x40 bolts
  - One charging cable
  - One external charger, 24 V DC, 10 A
- A MiR100 document folder containing a USB flash drive and the following printed documents:
  - *MiR100 Quick Start*
  - *The CE Declaration of Conformity for your robot*
  - *Getting the robot online*
  - *Passwords*
  - The unique nameplate for your robot
- The USB flash drive in the document folder has the following content:
  - *MiR100 User Guide*
  - *MiR100 Quick Start*
  - *MiR Network and WiFi Guide*
  - *MiR Robot Reference Guide*
  - *MiR Robot REST API Reference*
  - *Getting the robot online*
  - *CE Declaration of Conformity*

## 5.2 Unpacking MiR100

This section describes how to unpack the robot.



Keep the original packaging for future transportation of MiR100.

Follow these steps to unpack the robot:

1. Place the box with the robot so that there is three meters of free space at the front or the back of the box. This is necessary as the robot drives out of the box on a ramp.
2. Cut the protective straps surrounding the box.
3. Remove the lid from the box.

4. Take the folder with the printed documents and the USB flash drive out of the box.

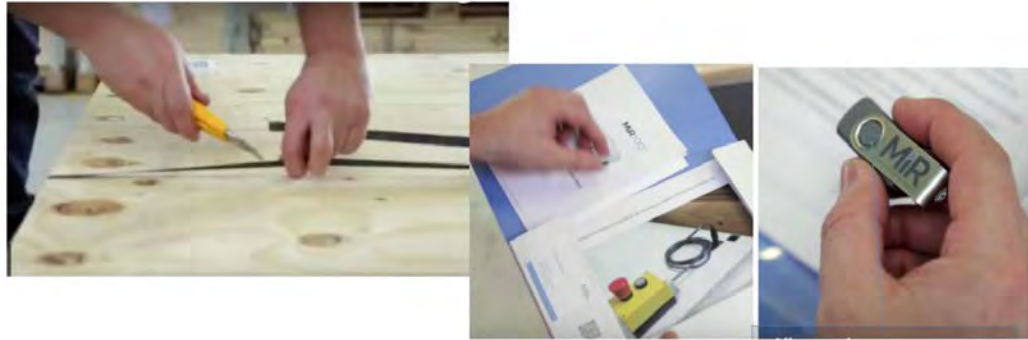

5. Remove the walls of the box and the protective foam blocks.

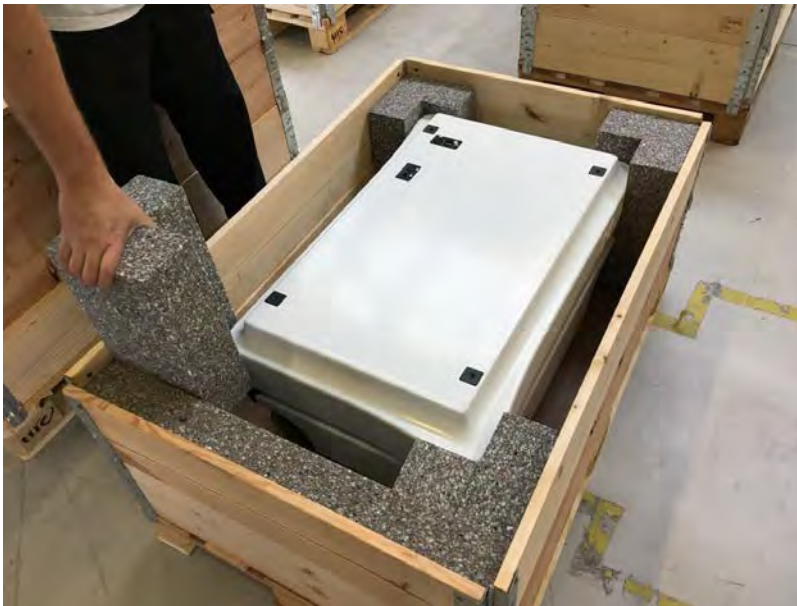

6. Place the lid of the box so that you can use it as a ramp at the robot's front or rear end. Align the lid so that it is flush with the base of the box.



## 5.3 Connecting the battery

Follow these steps to connect the battery to the robot:

1. Grab the two rounded corners and carefully lift off the cover.



2. Connect one of the two battery cables to the plug on top of the battery box. The second cable is for an extra battery.

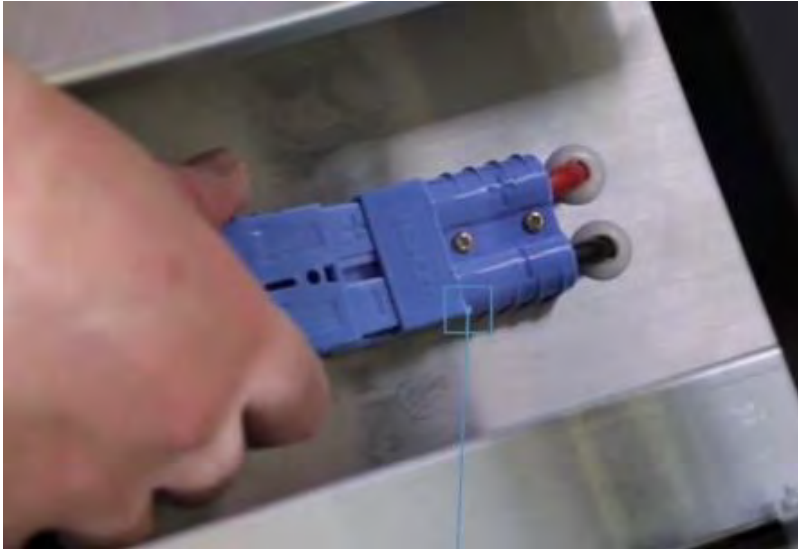

3. Switch on the three relays placed in the corner by the front laser scanner. Start with the outer relay that is closest to the robot frame and continue towards the center of the robot. The outer relay is the 32 A main power relay.



4. Ensure that the Battery disconnect switch, placed in the rear right corner, is on (the two yellow indicators pointing to On).



5. Put the cover back on and make sure to fit it correctly over the connector openings.



6. Mount and connect the Emergency stop box on top of the robot cover.



If a top module is going to be mounted on top of the robot, the Emergency stop must be placed in a position where it is easy to reach—see the mounting instructions for your top module.



7. Connect the antenna to the connector on top of the robot cover. Remove the plastic cap from the connector before fixing the antenna.



The antenna can be lowered and rotated in all directions to fit under a top module.

## 5.4 Powering up the robot

Follow these steps to power up the robot:

1. Press the Power button in the corner to turn on the robot. The status lights waver yellow, and the robot starts the software initialization process. When the initialization process ends, the robot goes into Protective stop.

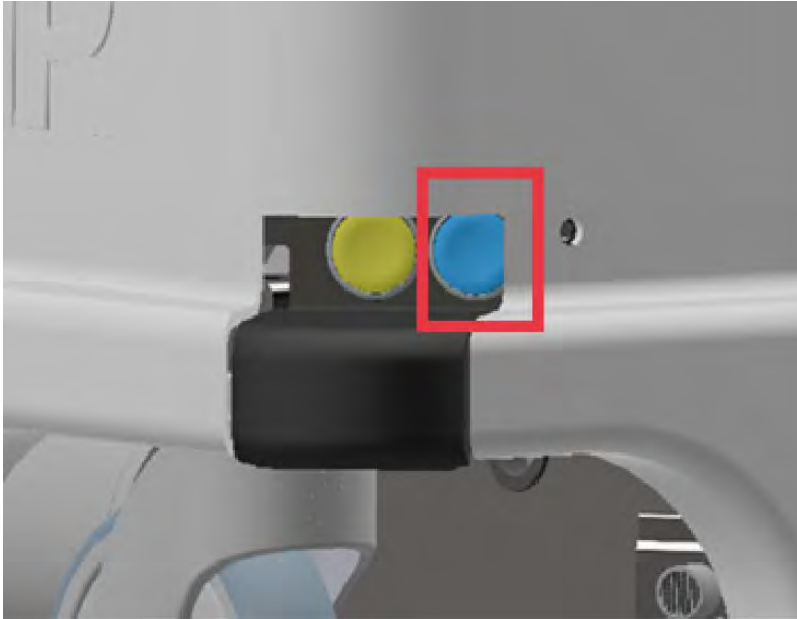

2. Press the reset button on the Emergency stop when the button lights up. The status lights switches to yellow constant light, indicating that the robot is paused and ready to

operate.



## 5.5 Connecting to the robot interface

When the robot is turned on, it enables the connection to its WiFi access point. The name of the access point appears in the list of available connections on your PC, tablet, or phone.



### NOTICE

The original username and password for the robot's web interface are in the document *Getting the robot online*.

The unique password for the WiFi access point is in the *Passwords* document.

Both documents are in the box with the product.

Follow these steps to connect to the robot interface:

1. Using your PC, tablet, or phone, connect to the WiFi access point of the robot using the unique password for the WiFi access point. The access point name has the following format: **MiR\_20XXXXXXX**.



The access point name is derived from the robot application's model serial number.



2. In a browser, go to the address **mir.com** and sign in.

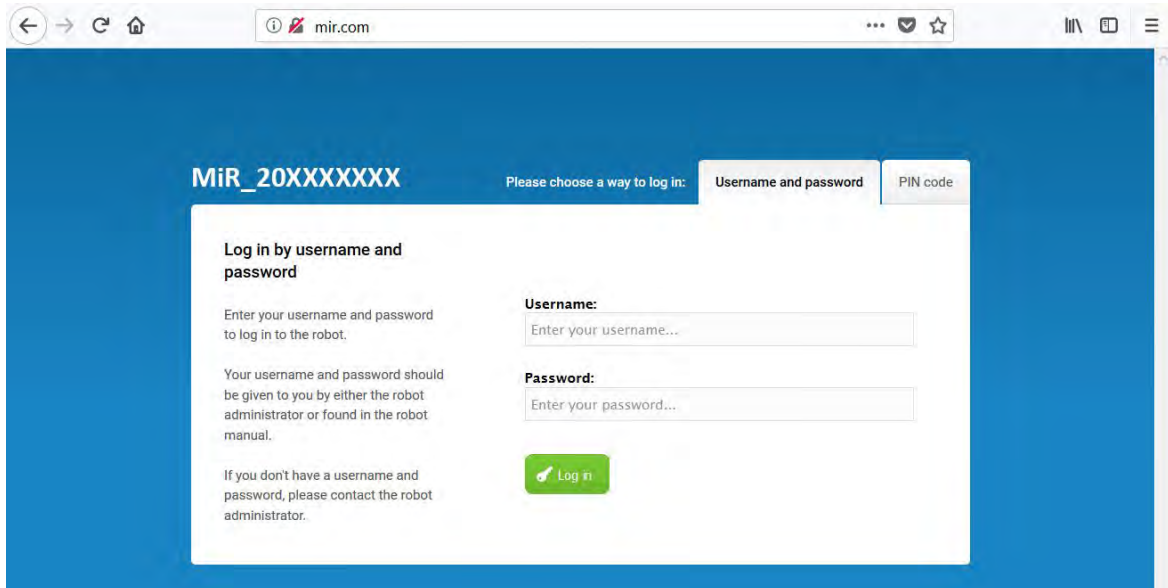

3. Switch to Manual mode, and drive the robot down the ramp—see [Driving the robot in Manual mode below](#).



## 5.6 Driving the robot in Manual mode



### CAUTION

When driving the robot in manual mode, it is possible to drive the robot into Forbidden zones and Unpreferred zones on the map. This can result in injury to personnel or damage to equipment if the robot is not driven carefully.

- Drive carefully to avoid collisions with any personnel or objects when driving the robot in Manual mode.
- Avoid driving the robot manually without a clear visual of the robot.

To drive the robot in Manual mode, follow these steps:

1. In the robot interface, select the joystick icon. The joystick control appears.



2. Drive the robot off the ramp using the joystick.



Place your foot in front of the ramp while the robot drives on it to keep the ramp from slipping.



## 5.7 Checking the hardware status

To check that all hardware components work as intended, follow these steps:

1. Sign in to the robot interface—see [Connecting to the robot interface](#) on page 27.
2. Go to **Monitoring > Hardware health**.
3. Check that all elements on the page have the **OK** status and that they have green dots on the left.

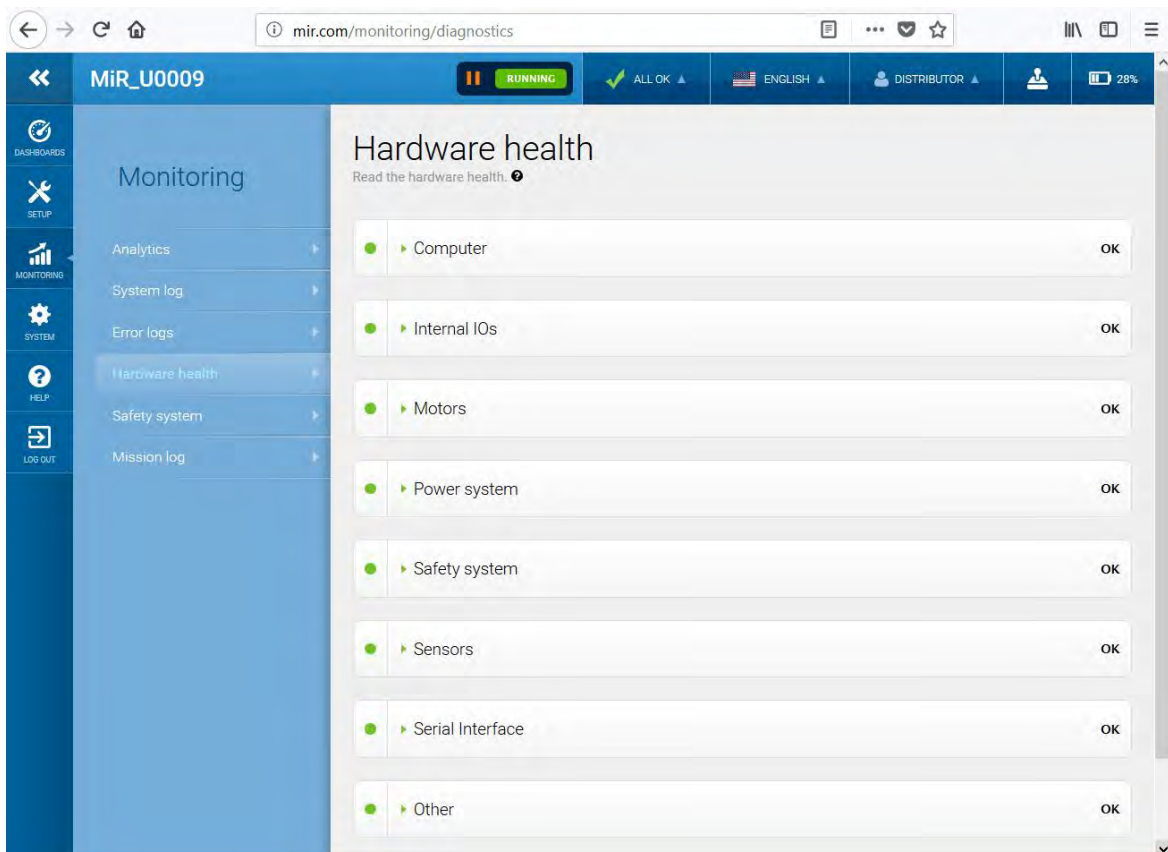

For more information, see [Hardware health](#) in *MiR Robot Reference Guide* on the MiR website.

## 5.8 Mounting the nameplate

Before using MiR100, you must mount its unique nameplate to it. The nameplate contains information specific to your MiR application.



**NOTICE**

The nameplate must be mounted as described in the following steps. If mounted incorrectly, the CE mark is invalid.

The following steps describe how to mount the nameplate correctly:

1. Locate the area below the side cover near the swivel wheel at the rear end of the robot.
2. Clean the area marked in the image below with a degreasing agent. If you cannot access the area, either lift the robot to an appropriate height or remove the top cover to gain access.

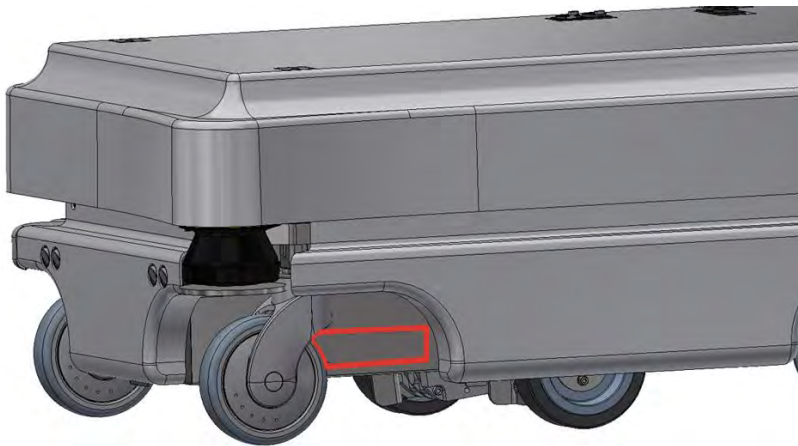

3. Mount the nameplate on the cleaned area.

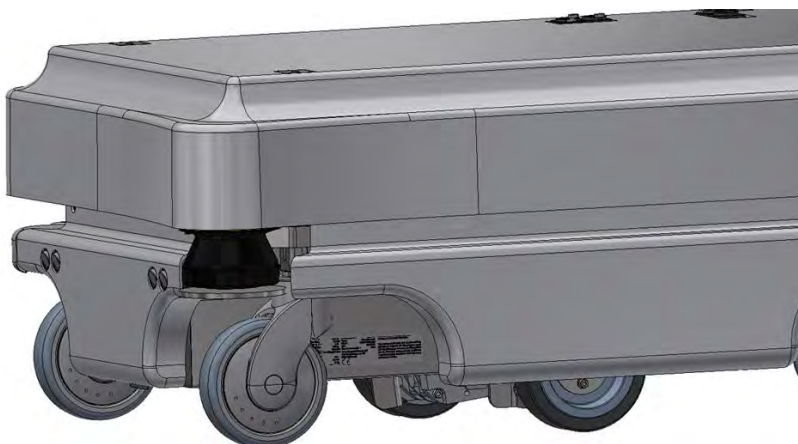



## 5.9 Shutting down the robot

Follow these steps to shut down MiR100:

1. Ensure that the robot is not moving or executing an action.
2. Press the Power button for three seconds.

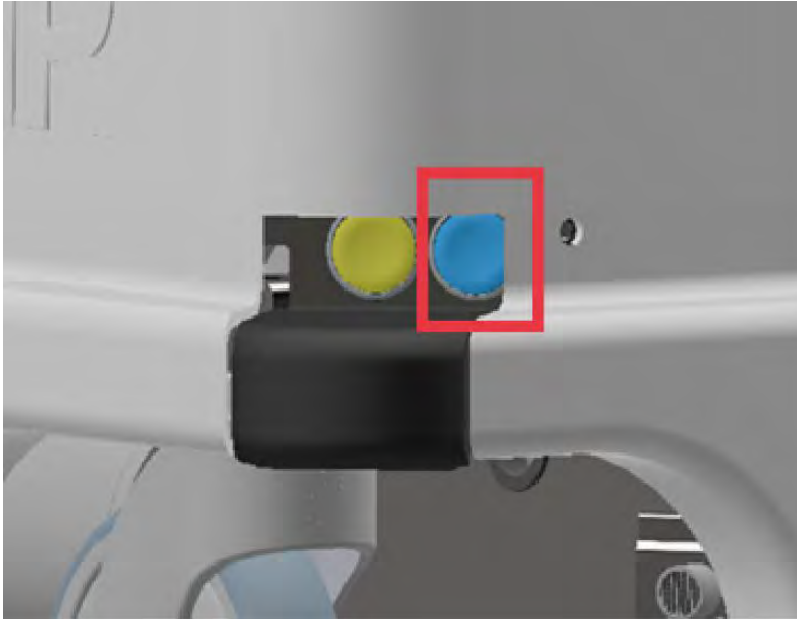

3. The robot starts the shutdown process. The status lights waver yellow.
4. When the robot finishes the shutdown process, the status lights are off.

When you shut down the robot for transportation, service, or repair, the battery must be disconnected—see *MiR100 User Guide*.



## Copyright and disclaimer

All rights reserved. No parts of this document may be reproduced in any form without the express written permission of Mobile Industrial Robots A/S (MiR). MiR makes no warranties, expressed or implied, in respect of this document or its contents. In addition, the contents of the document are subject to change without prior notice. Every precaution has been taken in the preparation of this document. Nevertheless, MiR assumes no responsibility for errors or omissions or any damages resulting from the use of the information contained.

Copyright © 2016-2020 by Mobile Industrial Robots A/S.

Contact the manufacturer:

Mobile Industrial Robots A/S

Emil Neckelmanns Vej 15F

DK-5220 Odense SØ

[www.mobile-industrial-robots.com](http://www.mobile-industrial-robots.com)

Phone: +45 20 377 577

Email: [support@mir-robots.com](mailto:support@mir-robots.com)

CVR: 35251235